

Anschluss Drehstrommotor und Thermischer Motorschutz über Klemmenblock

Three Phase motor and thermal protection connection by
 means of CAGE CLAMP®

Correspondance le moteur de courant triphasé et la protection de moteur thermique
 sur le bloc de pinces

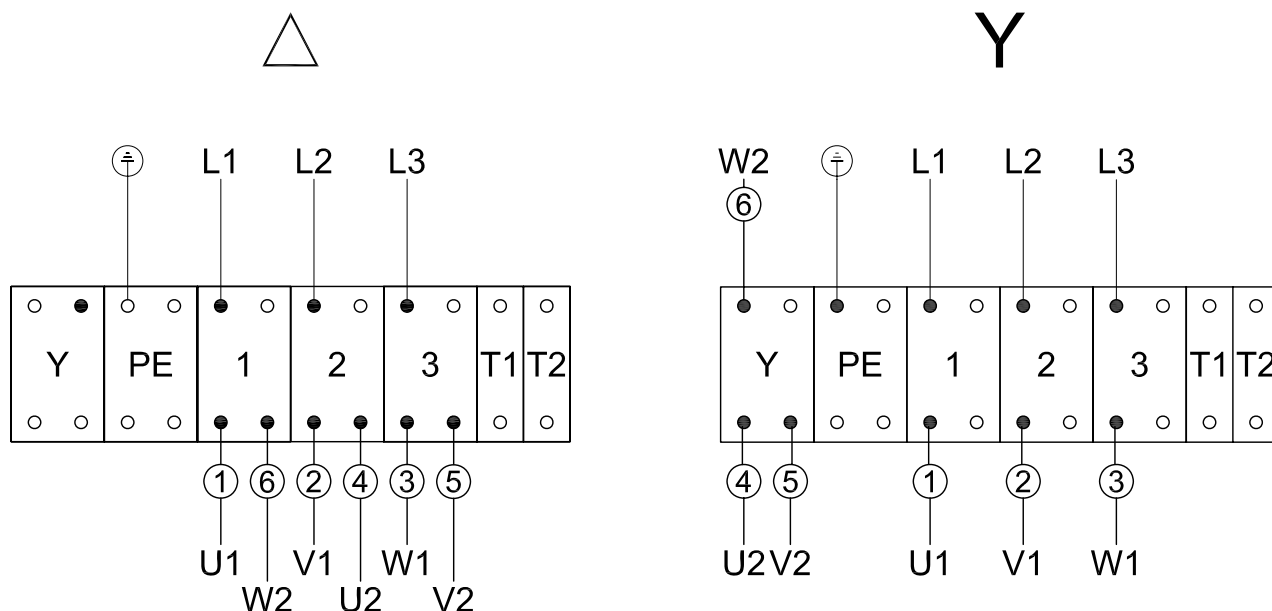

	IEC / EN 60034-8	NEMA MG 1	Farbe	Colour	Couleur
Netzanschluss Supply lines Branchement réseau	L1 L2 L3	L1 L2 L3			
Motorwicklung Motor winding	U1 V1 W1	T1 T2 T3	schwarz blau braun	black blue brown	noir bleu marron
Bobinage du moteur	U2 V2 W2	T4 T5 T6	gelb rot violett	yellow red violet	jaune rouge violet
	Schaltung für niedrige Nennspannung (z.B.: 230 V)		Connections for the low rated voltage (e.g.: 230 V)		Couplage basse tension nominale (230 V p. ex.)
	Schaltung für hohe Nennspannung (z.B.: 400 V)		Connections for the high rated voltage (e.g.: 400 V)		Couplage haute tension nominale (400 V p. ex.)
T1 T2	Thermischer Motorschutz	Thermal motor protection	Protect therm. Moteur		