

allseitig bearbeitet/ completely machined/ usiné complètement

Code -8./

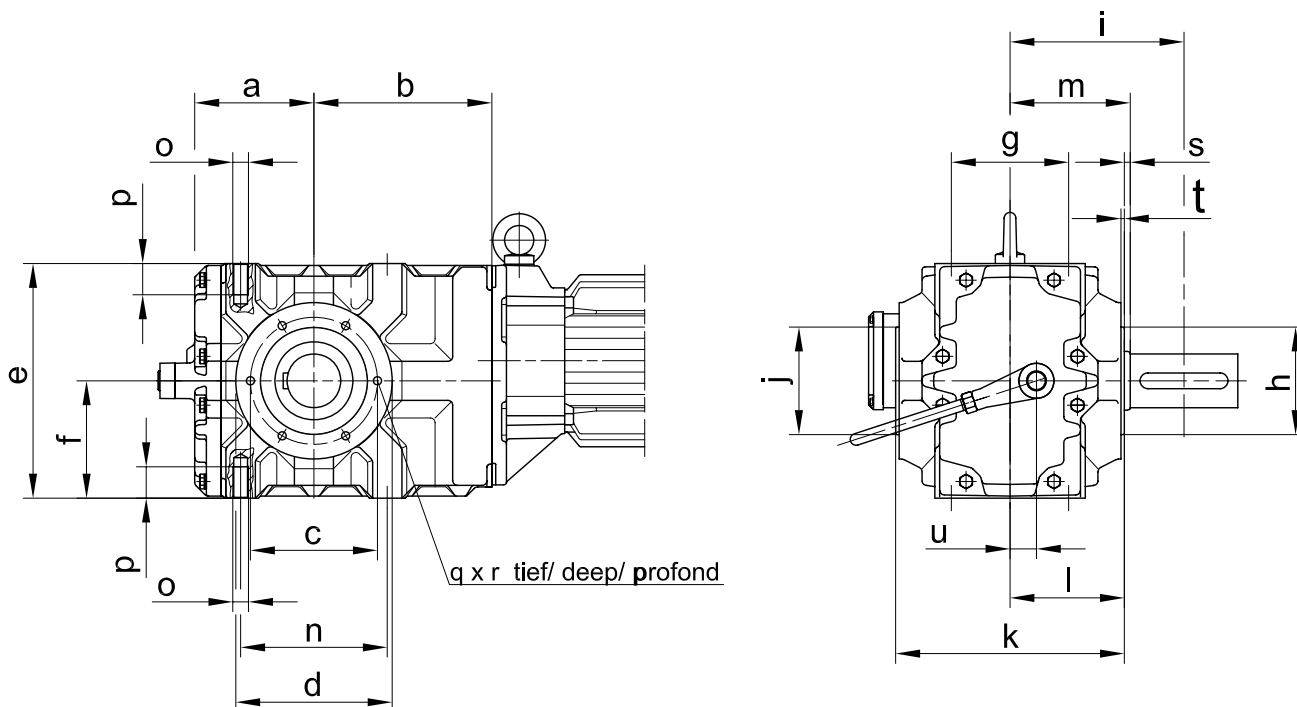

Getriebegrösse Gear size Taille réducteur	a	b	Øc	Ød	e	f	g	Øh	i	Øj	k	l	m	n	o	p	q	r	s	t	u
BM10	75.5	98	95	114	135	60	100	74 _{j6}	129	74 _{j6}	184	84	116	100	M12	22	M8	16	32	8	18
BM20	80	132	95	110	148	68	100	74 _{j6}	123.5	95 _{j6}	176	94	82	100	M12	24	M8	16	0	8	13
BM30	107.5	171	130	160	220	90	100	110 _{j6}	133	110 _{j6}	184	92	108.5	100	M12	24	M10	20	20	3.5	30.4
BM40	122	182	130	160	240	120	120	110 _{j6}	178	110 _{j6}	234	117	123	100	M16	32	M10	20	6	3.5	27