

Normallänge der Antriebseinheit + ML  
 Normal length of drive unit + ML  
 Longueur normale de l'unité d'entraînement + ML

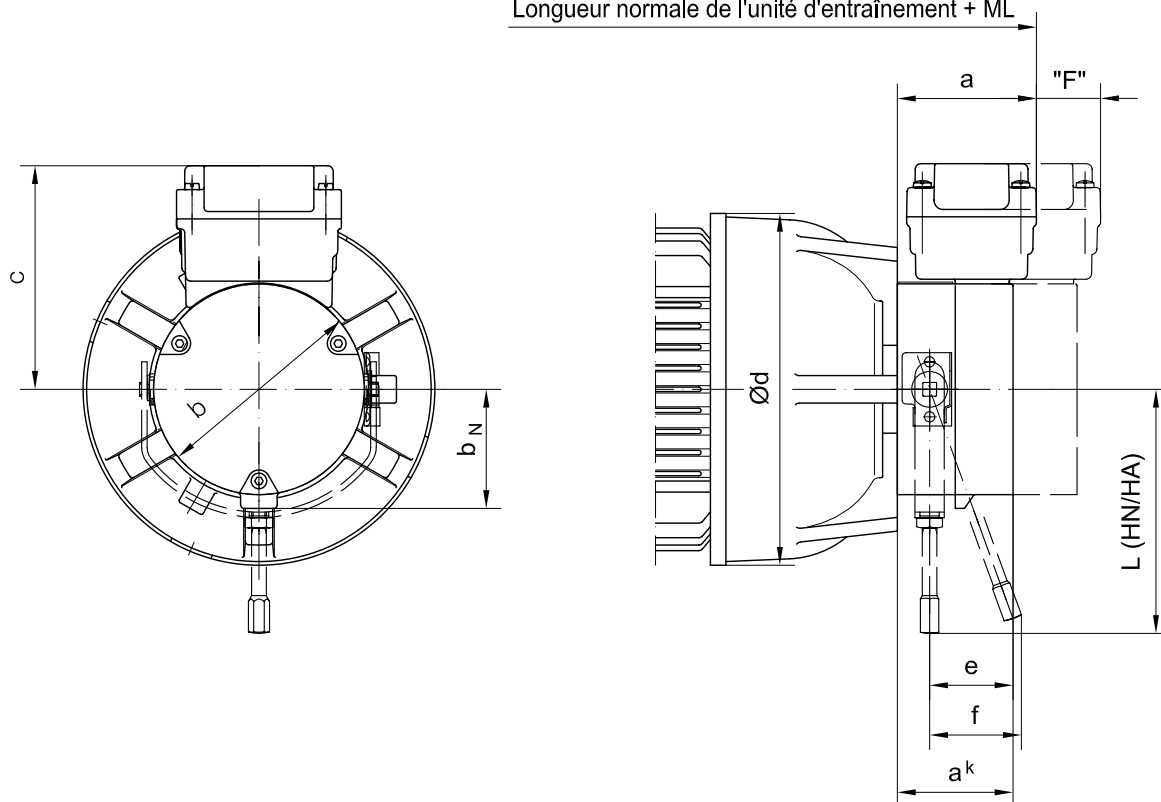

Motor	Bremse	ML(mm) Mehrlänge mit Bremse	Masse (mm)									Mehrgewicht	Freiraum zur Demontage der Bremse "F"
Motor	Brake	ML(mm) Additional length with brake	Dimensions (mm)									Add. weight	Free space for removing brake "F"
Moteur	Frein	ML(mm) Longueur supplémentaire pour frein	Dimensions (mm)									Poids suppl.	Dégagement pour démontage du frein "F"
			a	a <sup>k</sup>	b	b <sub>N</sub>	c	d	e	f	L	kg	
<b>Einscheibenbremse / Single-disc brake / Frein monodisque</b>													
D08	EK.008	87	76	63	115	65	123	166	45.5	57.5	156	6.5	30
D09	EK.008	92	76	63	115	65	123	192	45.5	57.5	156	6.5	30
<b>Zweischeibenbremsen / Double-disc brakes / Freins bidisques</b>													
D09	ZK.008	106	90	77	115	65	123	192	45.5	57.5	156	10.5	41
	ZK.015	108	92	83	131	76	136	192	49.5	64.5	175	12.5	41
D11	ZK.015	111	92	83	131	76	136	231	49.5	64.5	175	13	41